

movable glass door with frame & parking

PARKING SYSTEM

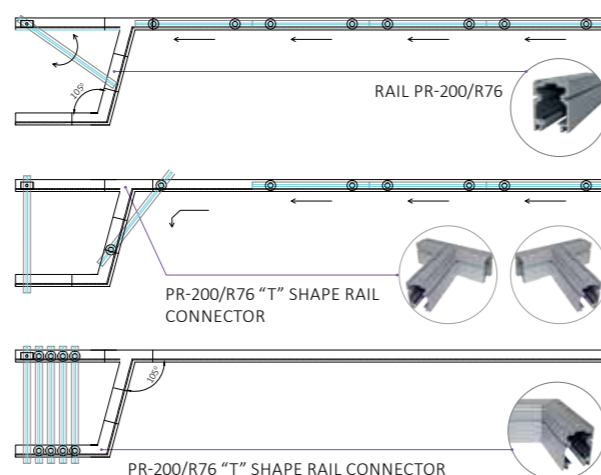

INAL® Framed Parking System FRP-75/R76 with heavy duty certified aluminum rail 55 mm x 76 mm with **embedded stainless steel rod & certified stainless steel rollers**. Special designed aluminum profiles create a strong frame for a variety of glass such as tempered up to 12mm, laminated up to 6+6, double glazing with a total thickness of up to 18mm. High resistance female & male vertical profiles for the maximum weather proofing between framed panels in combination with adjustable side aluminum case profiles. Ability to create swing door panel with overhead concealed door closer in intermediate sections of openings (FRP75/R76 SOC). Locking with eurocylinder or front bolts.



PARKING APPLICATIONS

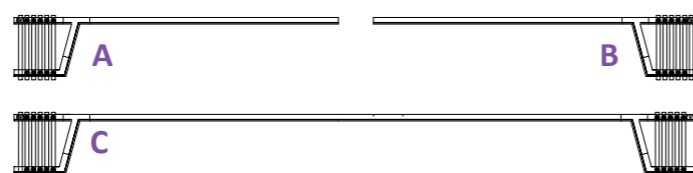

technical specifications

GLASS TYPE	DOUBLE GLAZING TEMPERED OR LAMINATED
GLASS THICKNESS	max 18mm
PANEL WEIGHT	max 100kg
MAXIMUM PANEL WIDTH	1,00m
MAXIMUM OPENING HEIGHT	3,00m
TYPE OF FRP-75/R76 SYSTEM	FRONT LOCKING
FINISHING	NATURAL ANODIZED, SATIN ANODIZED, RAL POWDER COATING
WITHOUT FLOOR GUIDE, NO GLASS CUTTINGS REQUIRED	

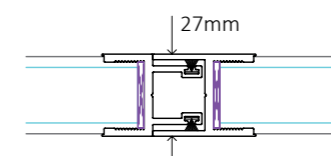
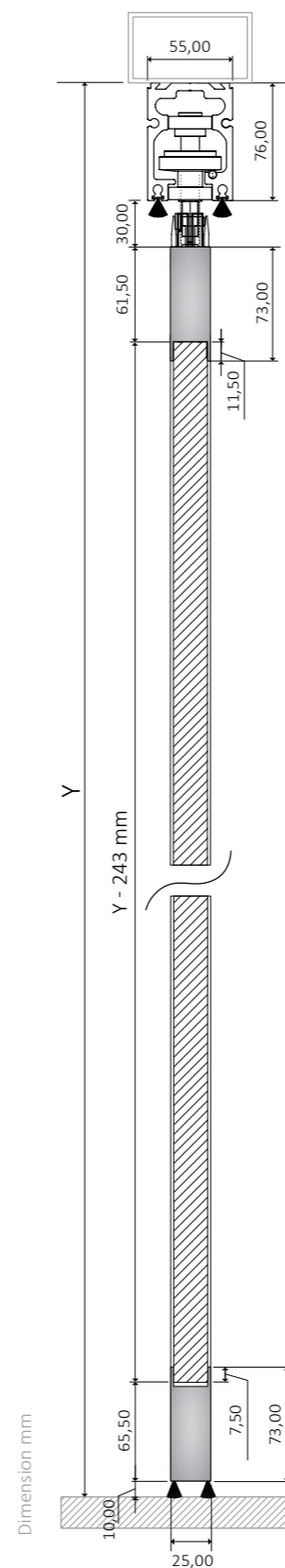

locking options

FRONT LOCKING



NO GLASS CUTTINGS REQUIRED

GLASS (TEMPERED OR LAMINATED OR DOUBLE GLAZING) DIMENSION CALCULATION

Glass height (mm) = Y - 243mm, (Y = from the bottom of the steel beam)